

# GLASS/WINDOWS/MIRRORS

# GW

---

	<b>Page</b>
1. General Description .....	2
2. Power Window System .....	6
3. Power Window Control Switch .....	7
4. Remote Control Mirror System.....	10
5. Outer Mirror Assembly .....	11
6. Outer Mirror.....	13
7. Remote Control Mirror Switch .....	14
8. Front Door Glass.....	16
9. Front Regulator and Motor Assembly .....	20
10. Rear Door Glass .....	21
11. Rear Regulator and Motor Assembly .....	23
12. Windshield Glass .....	24
13. Inner Rearview Mirror.....	27
14. Rear Gate Glass .....	28
15. Rear Window Defogger System.....	29
16. Rear Window Defogger.....	30
17. Rear Quarter Glass .....	31
18. Roof Window Glass.....	32

# GENERAL DESCRIPTION

GLASS/WINDOWS/MIRRORS

## 1. General Description

### A: COMPONENT

#### 1. FIXED GLASS

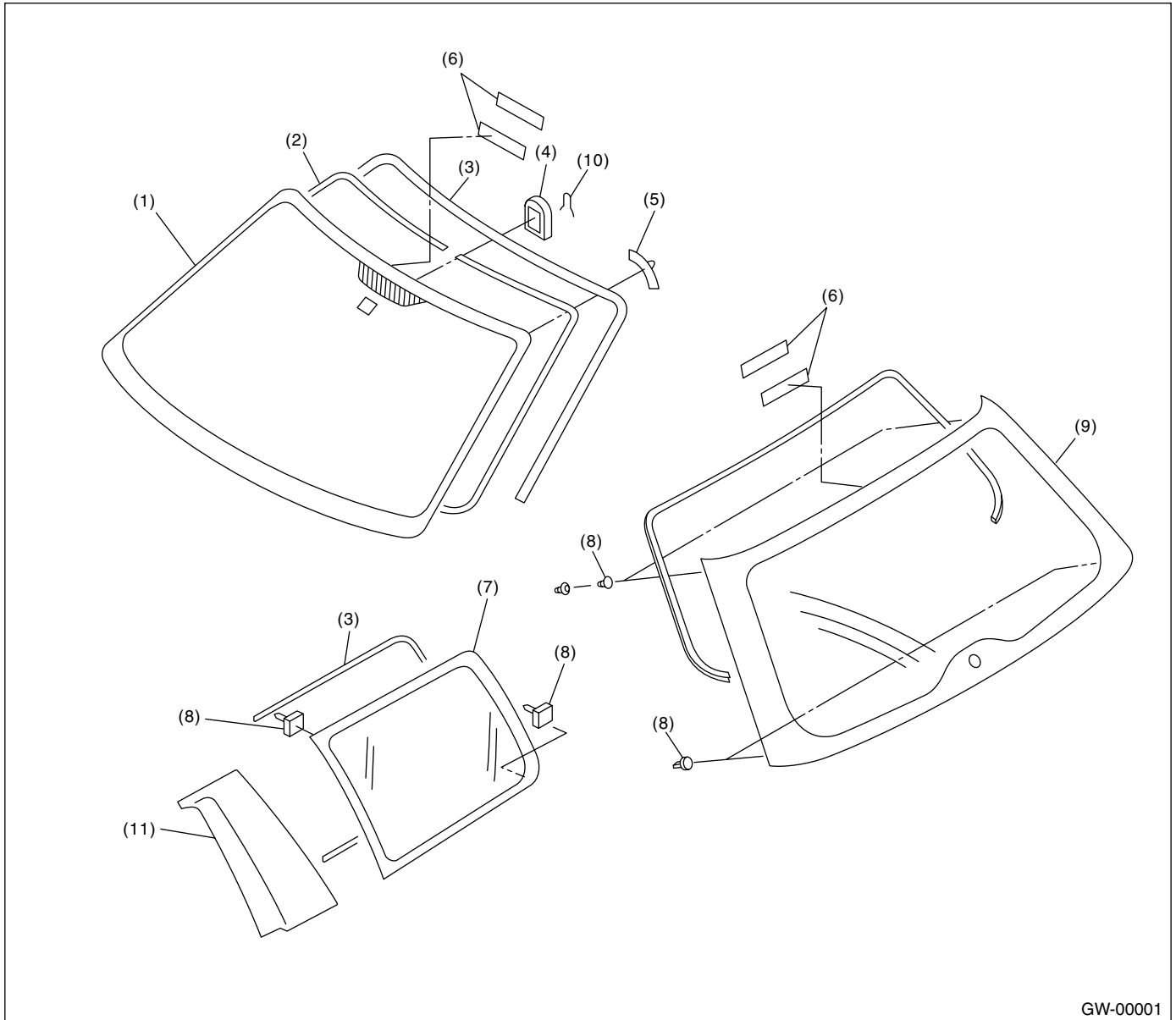

GW-00001

- |                           |                        |                     |
|---------------------------|------------------------|---------------------|
| (1) Windshield glass      | (5) Locate pin         | (9) Rear gate glass |
| (2) Dam rubber            | (6) Fastener           | (10) Spring         |
| (3) Molding               | (7) Rear quarter glass | (11) Cover C pillar |
| (4) Rearview mirror mount | (8) Locate pin         |                     |

## 2. FRONT DOOR GLASS

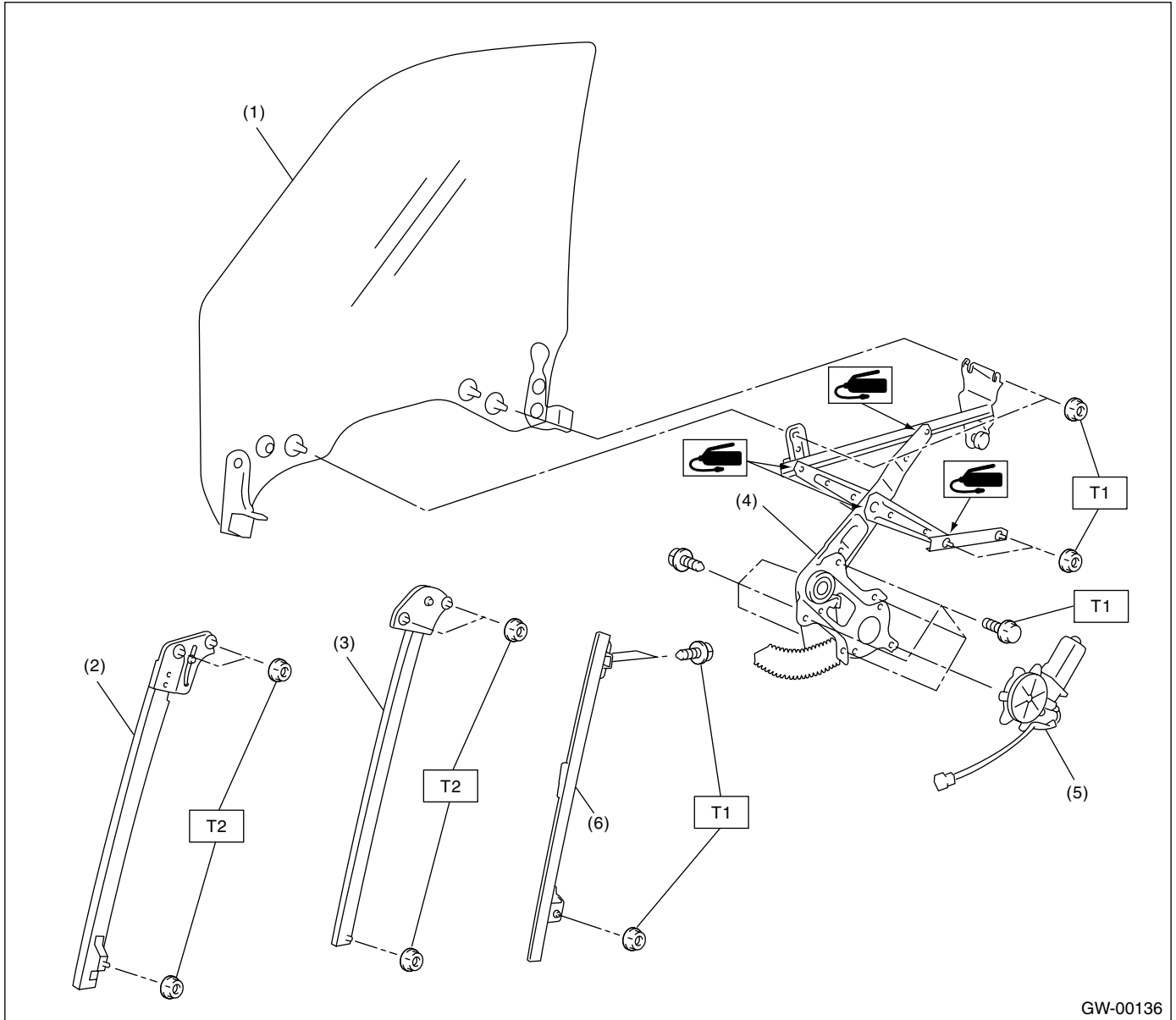

- (1) Glass
- (2) Door sash (Front)
- (3) Door sash (Rear)

- (4) Regulator ASSY
- (5) Motor ASSY
- (6) Guide rail

**Tightening torque: N-m (kgf-m, ft-lb)**

**T1: 7.4 (0.75, 5.5)**

**T2: 13.7 (1.4, 10.1)**

# GENERAL DESCRIPTION

GLASS/WINDOWS/MIRRORS

## 3. REAR DOOR GLASS

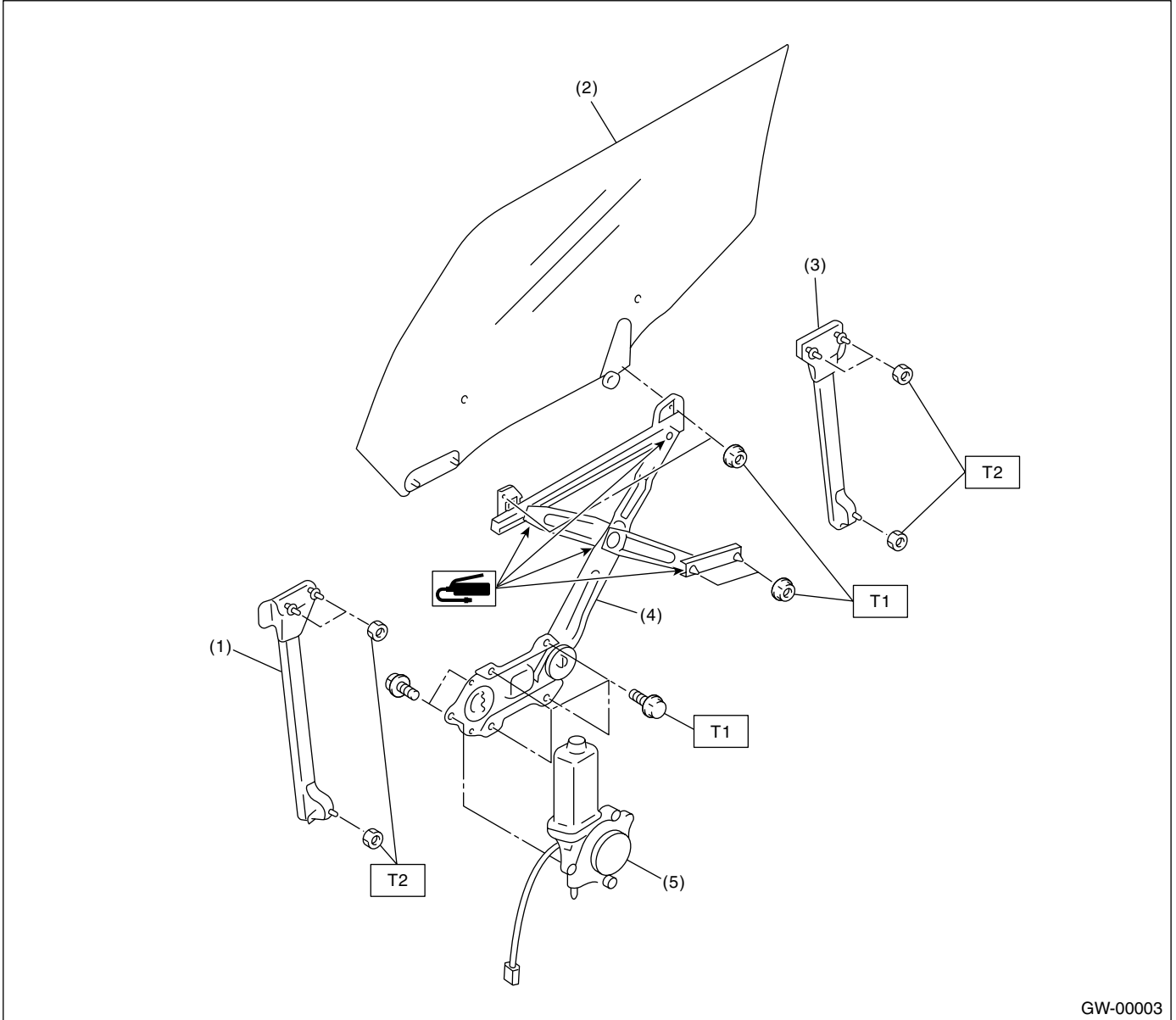

- (1) Door sash (Front)
- (2) Glass
- (3) Door sash (Rear)

- (4) Regulator ASSY
- (5) Motor ASSY

**Tightening torque: N-m (kgf-m, ft-lb)**

**T1: 7.4 (0.75, 5.5)**

**T2: 13.7 (1.4, 10.1)**

## 4. MIRRORS

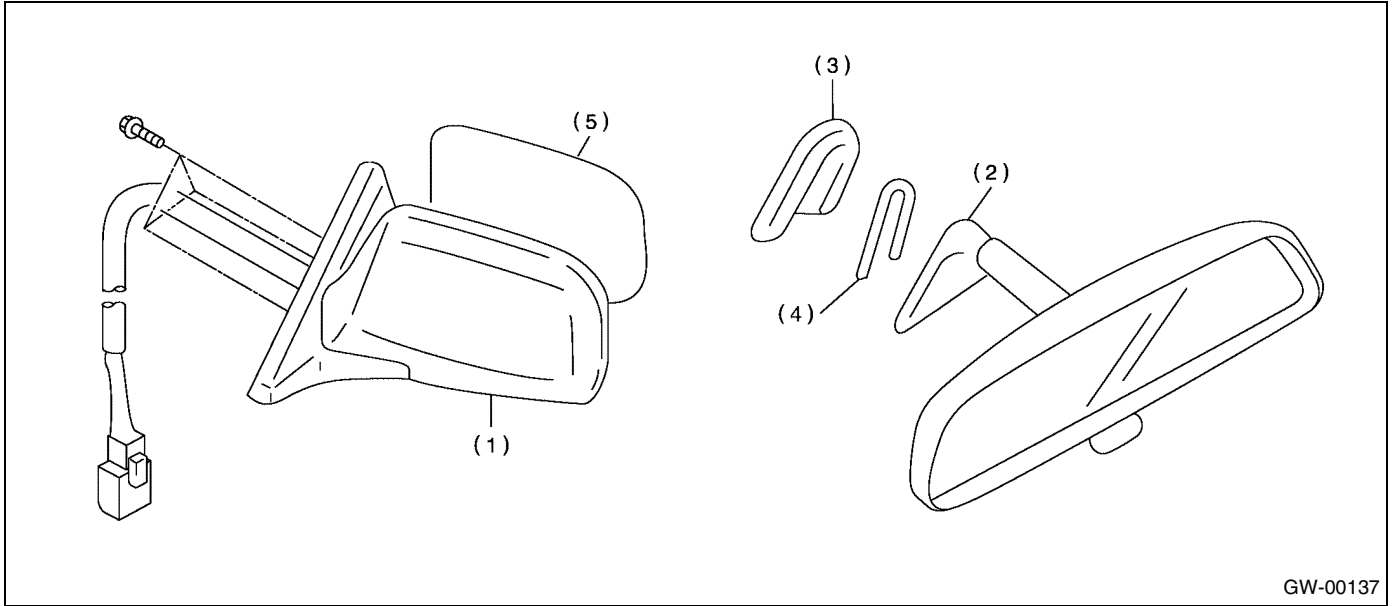

- (1) Outer mirror
- (2) Inner rearview mirror

- (3) Mount
- (4) Spring

- (5) Mirror

## B: PREPARATION TOOL

TOOL NAME	REMARKS
Circuit Tester	Used for checking voltage and continuity.
Piano Wire	Used for window glass removal.
Windshield Knife	Used for window glass removal.

# POWER WINDOW SYSTEM

GLASS/WINDOWS/MIRRORS

---

## 2. Power Window System

### A: SCHEMATIC

#### 1. POWER WINDOW (LHD MODEL)

<Ref. to WI-195, LHD MODEL, SCHEMATIC, Power Window System.>

#### 2. POWER WINDOW (RHD MODEL)

<Ref. to WI-199, RHD MODEL, SCHEMATIC, Power Window System.>

### B: INSPECTION

Symptom	Repair order
All power windows does not operate.	(1) Fuse (SBF-6) (2) Power window circuit breaker (3) Power window relay (4) Wire harness
One window does not operate.	(1) Power window main switch (2) Power window sub switch (3) Power window motor (4) Wire harness
"Window Lock" does not operate.	(1) Power window main switch

## 3. Power Window Control Switch

### A: REMOVAL

#### 1. MAIN SWITCH

- 1) Disconnect the ground cable from battery.
- 2) Using a flat tip screwdriver, remove the screw cover.

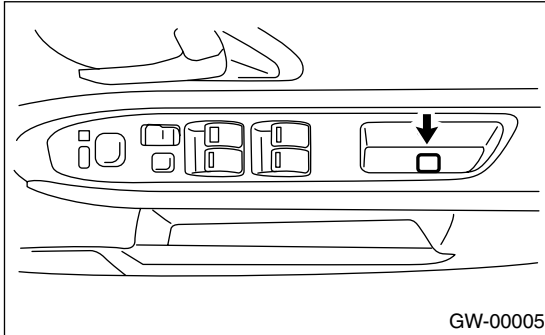

- 3) Loosen the screw to remove the power window main switch.

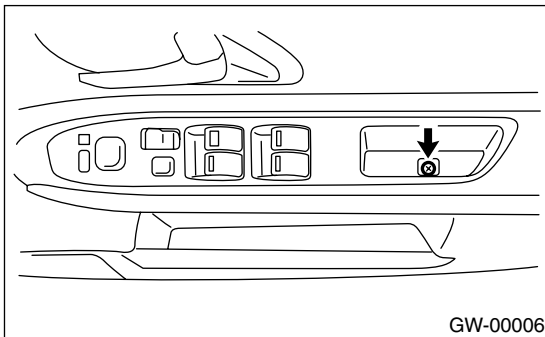

- 4) Disconnect the connector.

#### 2. SUB-SWITCH

- 1) Disconnect the ground cable from battery.
- 2) Remove the screw which secures switch panel.

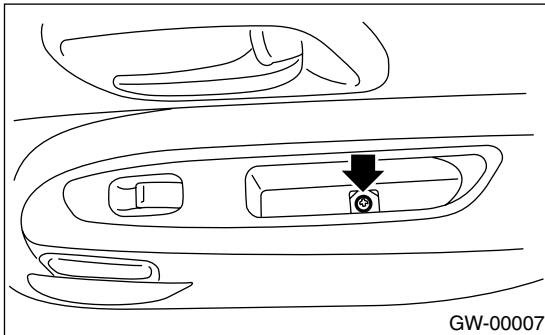

- 3) Remove the switch panel.

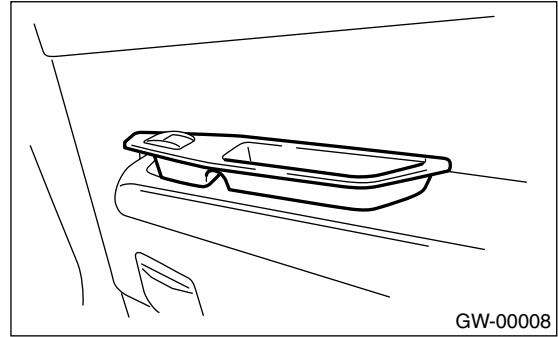

- 4) Disconnect the connector.

### B: INSTALLATION

#### 1. MAIN SWITCH

Install in the reverse order of removal.

#### 2. SUB-SWITCH

Install in the reverse order of removal.

# POWER WINDOW CONTROL SWITCH

GLASS/WINDOWS/MIRRORS

## C: INSPECTION

### 1. MAIN SWITCH

Measure the switch resistance.

#### • LHD model

##### Driver's switch:

Switch position	Terminal No.	Standard
AUTO UP	13 and 1, 2 and 5	Less than 1 $\Omega$
UP	13 and 1, 2 and 5	Less than 1 $\Omega$
OFF	1 and 2 1 and 5 2 and 5	Less than 1 $\Omega$
DOWN	13 and 2, 1 and 5	Less than 1 $\Omega$
AUTO DOWN	13 and 2, 1 and 5	Less than 1 $\Omega$

##### Front passenger's switch:

Switch position	Terminal No.	Standard
UP	13 and 7, 6 and 5	Less than 1 $\Omega$
OFF	5 and 6 5 and 7 6 and 7	Less than 1 $\Omega$
DOWN	13 and 6, 7 and 5	Less than 1 $\Omega$

##### Rear left switch:

Switch position	Terminal No.	Standard
UP	13 and 11, 10 and 1	Less than 1 $\Omega$
OFF	1 and 11 1 and 10 11 and 10	Less than 1 $\Omega$
DOWN	13 and 11, 10 and 5	Less than 1 $\Omega$

##### Rear right switch:

Switch position	Terminal No.	Standard
UP	13 and 16, 15 and 1	Less than 1 $\Omega$
OFF	1 and 15 1 and 16 15 and 16	Less than 1 $\Omega$
DOWN	13 and 15, 16 and 1	Less than 1 $\Omega$

If NG, replace the main switch.

#### • RHD model

##### Driver's switch:

Switch position	Terminal No.	Standard
AUTO UP	12 and 7, 6 and 1	Less than 1 $\Omega$
UP	12 and 7, 6 and 1	Less than 1 $\Omega$
OFF	1 and 6 1 and 7 6 and 7	Less than 1 $\Omega$
DOWN	12 and 6, 7 and 1	Less than 1 $\Omega$
AUTO DOWN	12 and 6, 7 and 1	Less than 1 $\Omega$



# POWER WINDOW CONTROL SWITCH

GLASS/WINDOWS/MIRRORS

## Front passenger's switch:

Switch position	Terminal No.	Standard
UP	12 and 2, 3 and 1	Less than 1 $\Omega$
OFF	1 and 2 1 and 3 2 and 3	Less than 1 $\Omega$
DOWN	12 and 3, 2 and 1	Less than 1 $\Omega$

## Rear left switch:

Switch position	Terminal No.	Standard
UP	12 and 10, 9 and 1	Less than 1 $\Omega$
OFF	1 and 9 1 and 10 9 and 10	Less than 1 $\Omega$
DOWN	12 and 9, 10 and 1	Less than 1 $\Omega$

## Rear right switch:

Switch position	Terminal No.	Standard
UP	12 and 14, 13 and 1	Less than 1 $\Omega$
OFF	1 and 13 1 and 14 13 and 14	Less than 1 $\Omega$
DOWN	12 and 13, 14 and 1	Less than 1 $\Omega$

If NG, replace the main switch.

## 2. SUB-SWITCH

Measure the switch resistance.

### Front passenger's door switch and rear door switch:

Switch position	Terminal No.	Standard
UP	8 and 5, 7 and 4, 1 and 8, 1 and 5	Less than 1 $\Omega$
OFF	6 and 5, 4 and 7	Less than 1 $\Omega$
DOWN	8 and 7, 5 and 6, 1 and 8, 1 and 7	Less than 1 $\Omega$

If NG, replace the sub-switch.

# REMOTE CONTROL MIRROR SYSTEM

GLASS/WINDOWS/MIRRORS

---

## 4. Remote Control Mirror System

### A: SCHEMATIC

#### 1. REMOTE CONTROL MIRROR

<Ref. to WI-210, SCHEMATIC, Remote Controlled Rearview Mirror System.>

### B: INSPECTION

Symptom	Repair order
All function does not operate.	(1) Fuse (F/B No. 4) (F/B No. 13) (F/B No. 17: LHD model) (F/B No. 18) (2) Mirror switch (3) Wire harness
One side of the mirror motor does not operate.	(1) Mirror switch (2) Mirror motor (3) Wire harness
Mirror heater does not operate.	(1) Mirror switch (2) Mirror heater (3) Wire harness

## 5. Outer Mirror Assembly

### A: REMOVAL

- 1) Remove the door trim. <Ref. to EI-35, REMOVAL, Front Door Trim.>
- 2) Remove the mirror gusset cover.

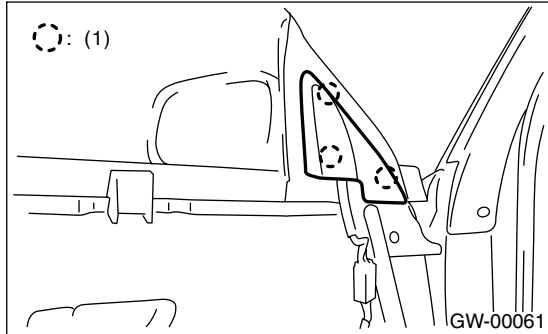

(1) Hook

- 3) Disconnect the mirror connector.
- 4) Remove the grommet, and loosen the screws to remove mirror assembly.

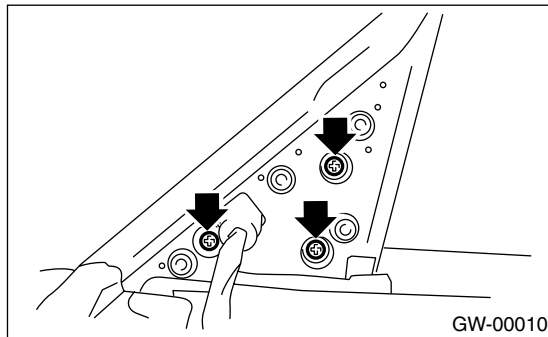

### B: INSTALLATION

Install in the reverse order of removal.

## OUTER MIRROR ASSEMBLY

GLASS/WINDOWS/MIRRORS

---

### C: INSPECTION

Check to ensure that the rearview mirror moves properly when battery voltage is applied to terminals.

#### Mirror heater not-equipped model:

Switch position	Terminal No.
OFF	—
UP	1 (+) and 3 (-)
DOWN	3 (+) and 1 (-)
LEFT	2 (+) and 3 (-)
RIGHT	3 (+) and 2 (-)

If NG, replace the mirror.

#### Mirror heater equipped model:

Switch position	Terminal No.
OFF	—
UP	2 (+) and 4 (-)
DOWN	4 (+) and 2 (-)
LEFT	3 (+) and 2 (-)
RIGHT	4 (+) and 3 (-)

If NG, replace the mirror.

## 6. Outer Mirror

### A: REPLACEMENT

- 1) Remove the door mirror assembly. <Ref. to GW-11, REMOVAL, Outer Mirror Assembly.>
- 2) Warm the area around the mirror holder with a hair drier until the edges of the mirror holder become soft (about 2 or 3 minutes with a 1,000 W drier.)
- 3) Use a flat tip screwdriver without sharp edges to lift the mirror out of the mirror holder. (Also disconnect the mirror heater connector from the back of mirror.)

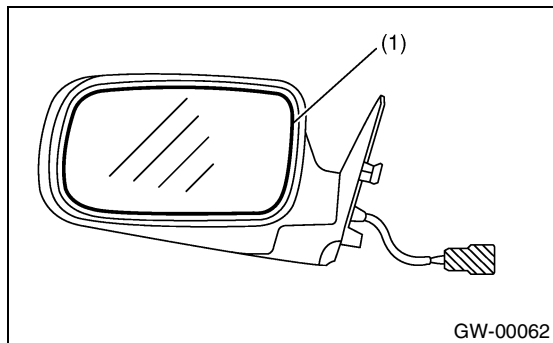

(1) Mirror holder

- 4) When installing the mirror, warm the area around the mirror holder with a hair drier until the edges of the mirror holder become soft again (about 2 or 3 minutes with a 1,000 W drier.)
- 5) Remove the backing of the new double-stick tape, and push the mirror in to install it.

**NOTE:**

Unless the mirror holder is warmed sufficiently, the mirror holder edges may be damaged or the mirror cracked.

## 7. Remote Control Mirror Switch

### A: REMOVAL

Refer to Power Window Control Switch, because the remote control mirror switch is integrated with power window control switch. <Ref. to GW-7, REMOVAL, Power Window Control Switch.>

### B: INSTALLATION

Refer to Power Window Control Switch, because the remote control mirror switch is integrated with power window control switch. <Ref. to GW-7, INSTALLATION, Power Window Control Switch.>

# REMOTE CONTROL MIRROR SWITCH

GLASS/WINDOWS/MIRRORS

## C: INSPECTION

Move the rearview mirror switch to each position and check continuity between terminals.

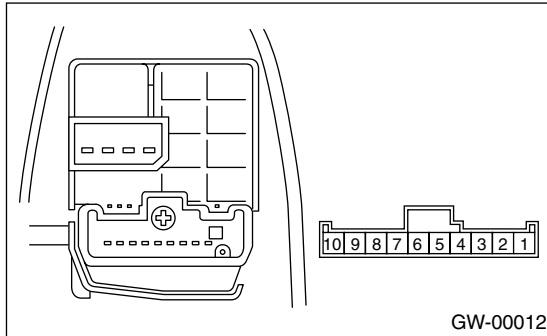

### Change over switch right position:

Switch position	Terminal No.	Standard
OFF	—	More than 1 M $\Omega$
UP	8 and 3, 6 and 7	Less than 1 $\Omega$
DOWN	8 and 6, 3 and 7	Less than 1 $\Omega$
LEFT	8 and 2, 6 and 7	Less than 1 $\Omega$
RIGHT	8 and 6, 2 and 7	Less than 1 $\Omega$

### Change over switch left position:

Switch position	Terminal No.	Standard
OFF	—	More than 1 M $\Omega$
UP	8 and 4, 6 and 7	Less than 1 $\Omega$
DOWN	8 and 6, 4 and 7	Less than 1 $\Omega$
LEFT	8 and 5, 6 and 7	Less than 1 $\Omega$
RIGHT	8 and 6, 5 and 7	Less than 1 $\Omega$

If NG, replace the switch.

# FRONT DOOR GLASS

GLASS/WINDOWS/MIRRORS

## 8. Front Door Glass

### A: REMOVAL

- 1) Remove the front door trim. <Ref. to EI-35, REMOVAL, Front Door Trim.>
- 2) Remove the front speaker. <Ref. to ET-6, INSTALLATION, Front Speaker.>
- 3) Remove the sealing cover. <Ref. to EB-13, REMOVAL, Front Sealing Cover.>
- 4) Remove the outer mirror assembly. <Ref. to GW-11, REMOVAL, Outer Mirror Assembly.>
- 5) Remove the front end of door weatherstrip and gusset.

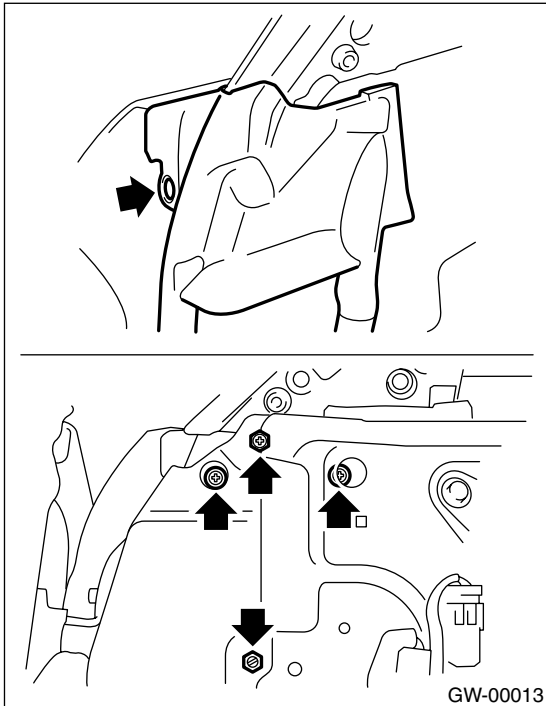

- 6) Remove the stabilizers.

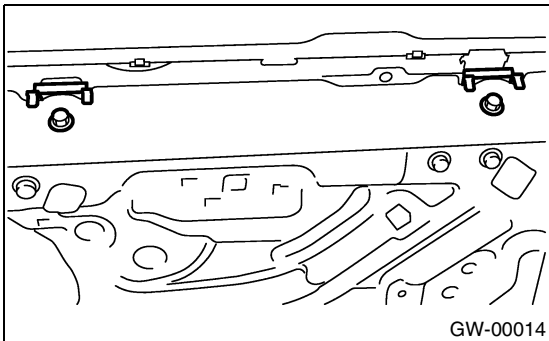

- 7) Remove the rear end of door weatherstrip and weatherstrip outer.

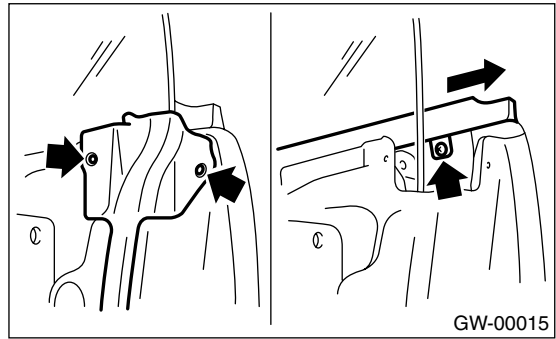

- 8) Operate the power window switch to move the glass to position shown in the figure, and then remove the two nuts from service holes.

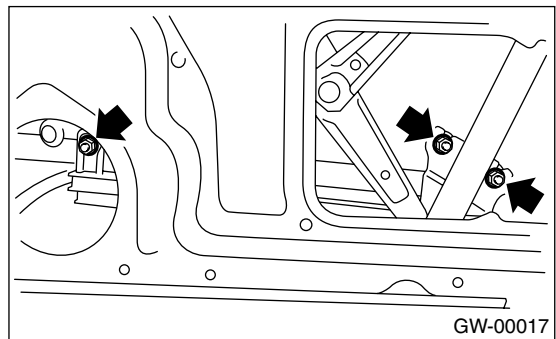

- 9) Take out the door glass.

#### NOTE:

- Do not turn the regulator in closing direction after removal of the glass. Otherwise gear may be disengaged.



## B: INSTALLATION

1) Install in the reverse order of removal.

### CAUTION:

**Make sure that the glass stay is placed securely in sash.**

2) Adjust the front door glass. <Ref. to GW-17, ADJUSTMENT, Front Door Glass.>

### Tightening torque:

Refer to **COMPONENT** in *General Description*. <Ref. to GW-3, **FRONT DOOR GLASS, COMPONENT, General Description.**> and <Ref. to GW-2, **FIXED GLASS, COMPONENT, General Description.**>

## C: ADJUSTMENT

### NOTE:

Before adjustment, ensure that all adjusting bolts of stabilizer, upper stopper, and sash are loose and door glass is raised so that it is in contact with weatherstrip.

1) Temporarily tighten one adjusting bolt on one side of rear sash at the midpoint of slotted hole in the inner panel.

2) Temporarily tighten the regulator B-channel in a position at the top of slotted hole.

3) Lower the door glass 10 to 15 mm (0.39 to 0.59 in) from fully closed position. While applying outward pressure of  $45.0 \pm 5$  N ( $4.6 \pm 0.5$  kg,  $11.0 \pm 1.1$  lb) to the point (F) of glass upper edge above midpoint of two outer stabilizers, press the inner stabilizer at pressure of  $25 \pm 5$  N ( $2.5 \pm 0.5$  kg,  $5.5 \pm 1.1$  lb) to the glass, then secure it.

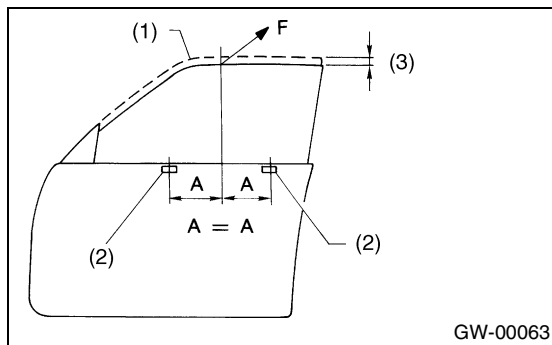

- (1) Full close
- (2) Stabilizer
- (3) 10 — 15 mm (0.39 — 0.59 in)

4) For adjustment of clearance between front door glass and center pillar cover, loosen the nuts (A), and move the rear sash back and forward until clearance becomes the value shown. (Difference between upper side and lower side must be within 1.5 mm (0.059 in).)

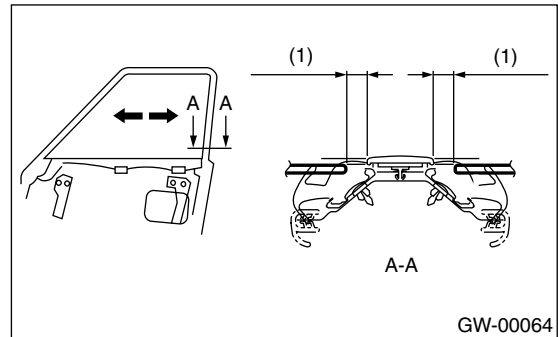
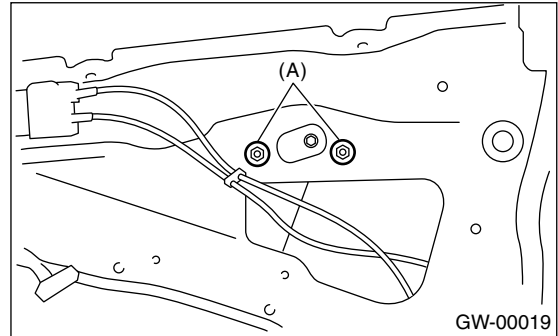

- (1)  $12 \pm 1$  mm ( $0.472 \pm 0.039$  in)

5) For adjustment of upper and lower ends of center pillar, loosen the adjusting nut (A) of B-channel (B).

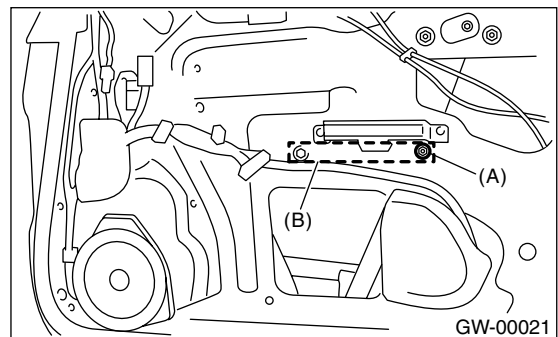

# FRONT DOOR GLASS

## GLASS/WINDOWS/MIRRORS

6) Adjust so that the upper and lower ends of center pillar are the same size.

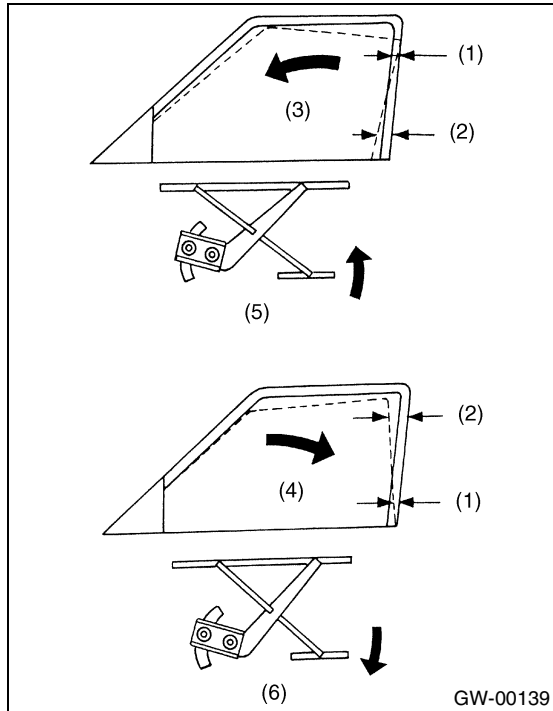

- (1) Narrow
- (2) Wide
- (3) Glass tilts too far rearward
- (4) Glass tilts too far forward
- (5) Raise B channel
- (6) Lower B channel

7) For glass stroke adjustment, close the door, raise glass until positional relationship between glass and weatherstrip becomes as shown. And secure the glass so that the upper stopper lightly touches the glass holder.

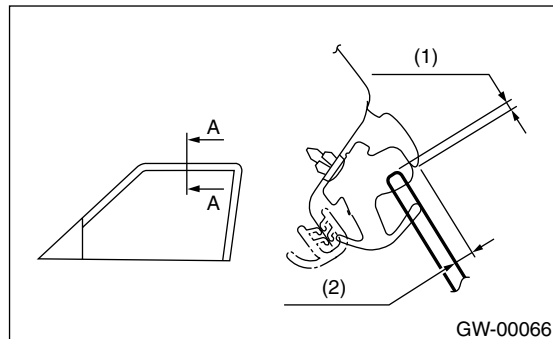

- (1)  $3.5 \pm 0.8$  mm ( $0.137 \pm 0.031$  in)
- (2)  $9.5 \pm 1$  mm ( $0.374 \pm 0.039$  in)

For preventing wind noise, adjust the glass at the position where tip of gusset is raised up a little.

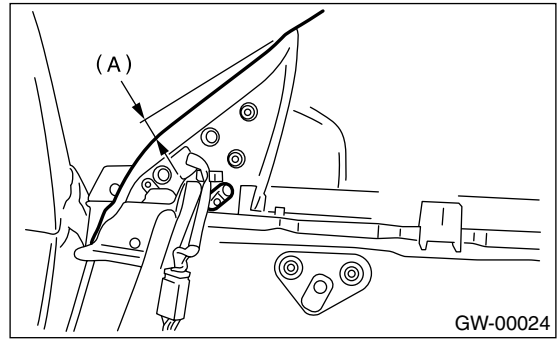

- (A) 0 — 1.5 mm (0 — 0.059 in)

8) After stabilizer adjustment, carry out the glass crimp adjustment. First, visually ensure positional relationship between retainer & molding and glass of the roof side, and then begin with rear sash adjustment. Adjust two adjusting bolts alternately step by step to obtain dimensions shown below (cross-section A).

### NOTE:

If two nuts are loosened at the same time, sash moves back and forth. Therefore, when one nut is adjusted, secure the other.

9) Make the same adjustment of two adjusting bolts of rear sash.

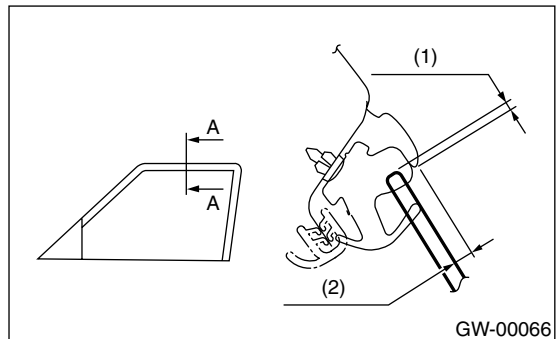

- (1)  $3.5 \pm 0.8$  mm ( $0.137 \pm 0.031$  in)
- (2)  $9.5 \pm 1$  mm ( $0.374 \pm 0.039$  in)

**NOTE:**

Do not tilt the sash bracket to inner panel during adjustment. Otherwise smooth regulator operation cannot be achieved.

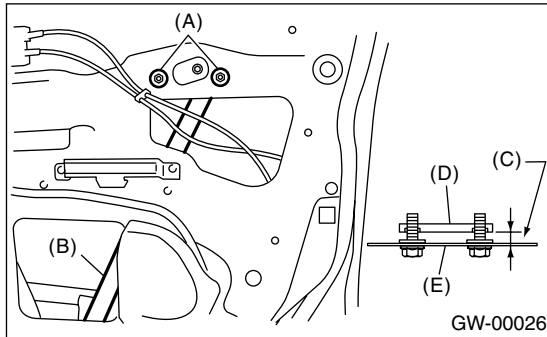

- (A) Sash bracket
- (B) Rear sash
- (C) Adjust a line parallel
- (D) Sash
- (E) Inner panel

10) Make adjustment of front sash in the same manner as that of rear sash.

**NOTE:**

Although front and rear sashes must, as a rule, be adjusted in the same manner, in some door installation, the adjustment in a different manner may be required. However, adjustment of one sash to the maximum amount and the other to the minimum amount is not permitted. Such adjustment may result in application of excessive load to regulator.

11) After adjustments, tighten the nuts.

12) After adjustment to glass, close the door. If there is even a little gap between outer lip of gusset and glass surface, adjust the gap with adjusting nut (A) in lower fitting part of the gusset to prevent generation of wind noise.

13) During adjustments, loosen the other three clamping screws.

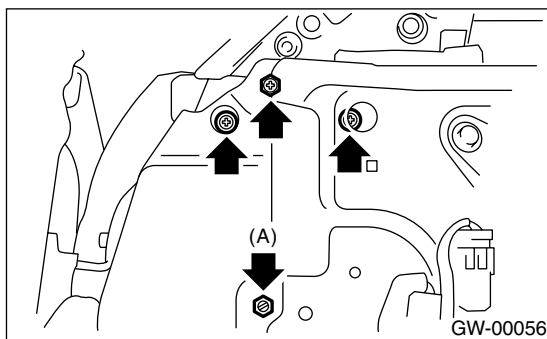

14) After adjustment, tighten the bolts and nuts.

# FRONT REGULATOR AND MOTOR ASSEMBLY

GLASS/WINDOWS/MIRRORS

## 9. Front Regulator and Motor Assembly

### A: REMOVAL

- 1) Remove the door glass. <Ref. to GW-16, REMOVAL, Front Door Glass.>
- 2) Loosen the nuts to remove rear sash.

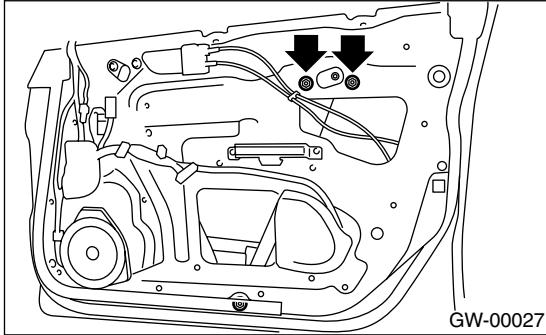

- 3) Disconnect the motor connector.
- 4) Loosen the four bolts and two nuts to remove regulator assembly.

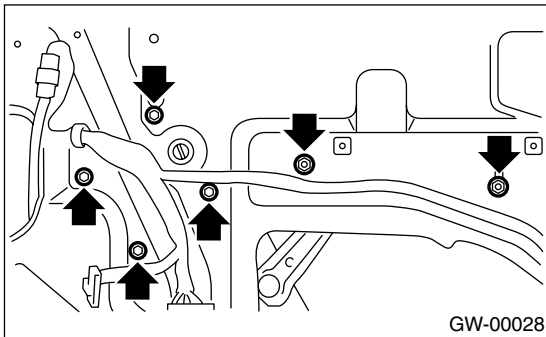

- 5) Loosen the screw to remove motor assembly.

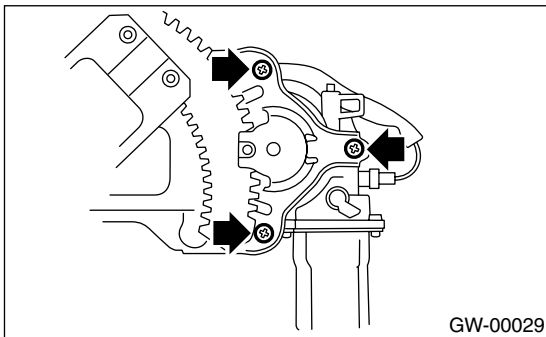

### B: INSTALLATION

- 1) Install in the reverse order of removal.
- 2) Adjust the front door glass. <Ref. to GW-17, ADJUSTMENT, Front Door Glass.>

#### *Tightening torque:*

*Refer to COMPONENT in General Description. <Ref. to GW-3, FRONT DOOR GLASS, COMPONENT, General Description.>*

### C: INSPECTION

- 1) Make sure that the power window motor rotates properly when battery voltage is applied to the terminals of motor connector.
- 2) Change polarity of battery connections to terminals to ensure that the motor rotates in reverse direction.

## 10. Rear Door Glass

### A: REMOVAL

- 1) Remove the rear door trim. <Ref. to EI-36, REMOVAL, Rear Door Trim.>
- 2) Remove the front speaker. <Ref. to ET-6, REMOVAL, Front Speaker.>
- 3) Remove the sealing cover. <Ref. to EB-16, REMOVAL, Rear Sealing Cover.>
- 4) Remove the stabilizer.

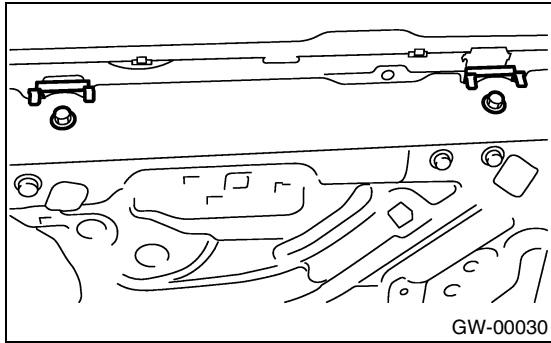

- 5) Remove the door weather strip.

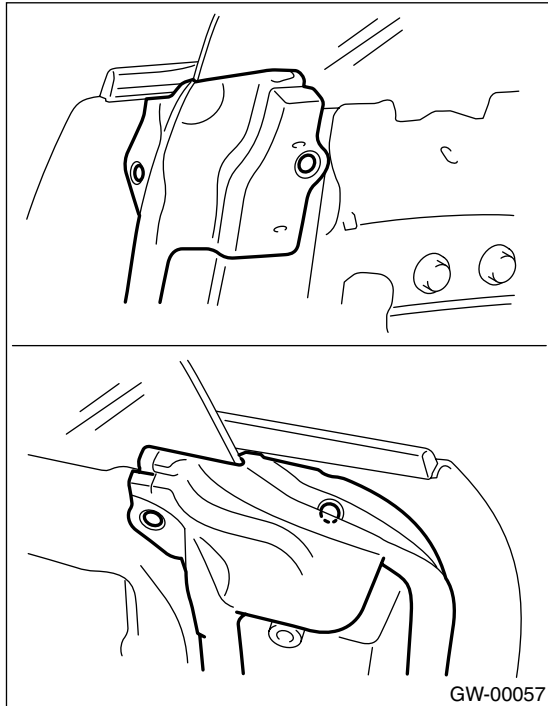

- 6) Loosen the two screws to remove the weather strip outer.

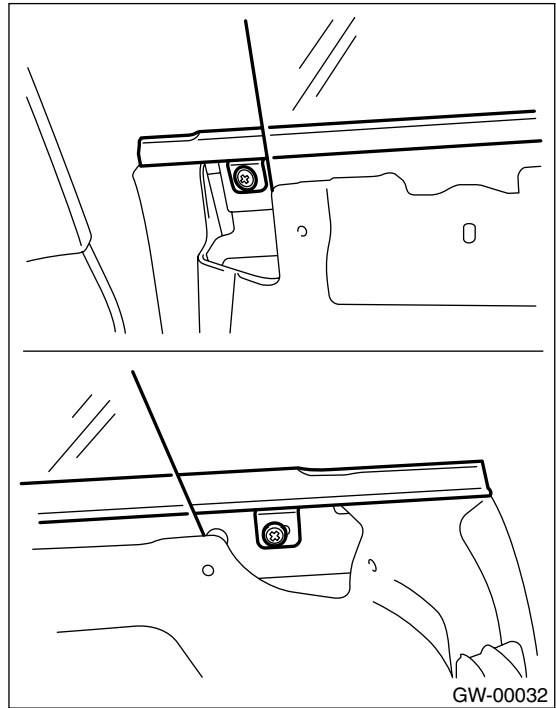

- 7) Operate the power window switch to remove glass as shown in the figure, and then remove two nuts.

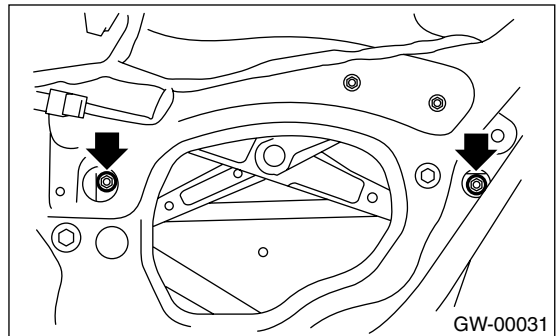

- 8) Take out the door glass.

# REAR DOOR GLASS

GLASS/WINDOWS/MIRRORS

## B: INSTALLATION

1) Install in the reverse order of removal.

### CAUTION:

**Make sure that the glass stay is placed securely in sash.**

2) Adjust the rear door glass. <Ref. to GW-22, ADJUSTMENT, Rear Door Glass.>

### Tightening torque:

Refer to **COMPONENT** in *General Description*. <Ref. to GW-4, **REAR DOOR GLASS, COMPONENT, General Description.**> and <Ref. to GW-3, **FRONT DOOR GLASS, COMPONENT, General Description.**>

## C: ADJUSTMENT

### NOTE:

The rear door glass, as a rule, should be adjusted in the same manner as front glass, although they are different in dimension. Special notes for the rear glass are given below.

1) Adjust the glass position using the following dimensions as a guide line. (Difference between upper side and lower side must be within 1.5 mm (0.059 in).)

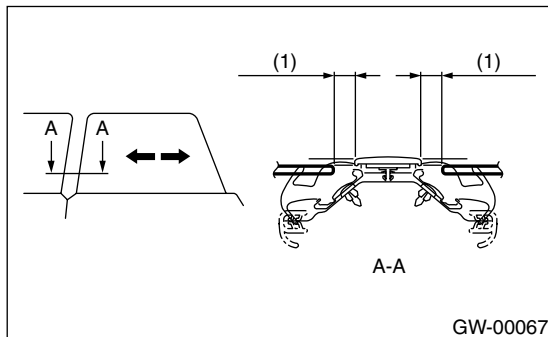

(1)  $12 \pm 1$  mm ( $0.472 \pm 0.039$  in)

### NOTE:

- If the dimensions are smaller than the given dimensions, glass may get caught in weatherstrip during lifting/lowering operation. In the worst case, it may cause the glass not to be opened fully.
- After adjustment, move the glass up and down to check whether it is caught.

2) Adjust the crimp of glass using the following dimensions as a guide line.

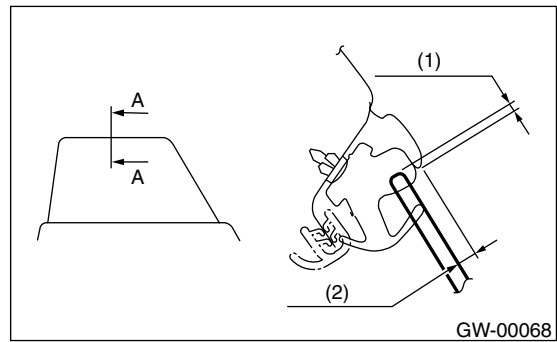

(1)  $3.5 \pm 0.8$  mm ( $0.137 \pm 0.031$  in)

(2)  $9.5 \pm 1$  mm ( $0.374 \pm 0.039$  in)

### NOTE:

- If the crimp of rear glass is higher than necessary, glass may get caught in weatherstrip of center pillar corner, resulting in early wear of weatherstrip. Be careful when adjusting.
- After adjustment, move the glass up and down to check whether it is caught.

## 11. Rear Regulator and Motor Assembly

### A: REMOVAL

- 1) Remove the door glass. <Ref. to GW-21, REMOVAL, Rear Door Glass.>
- 2) Remove the front sash.
- 3) Disconnect the motor connector.
- 4) Loosen the four bolts and two nuts to remove regulator assembly.

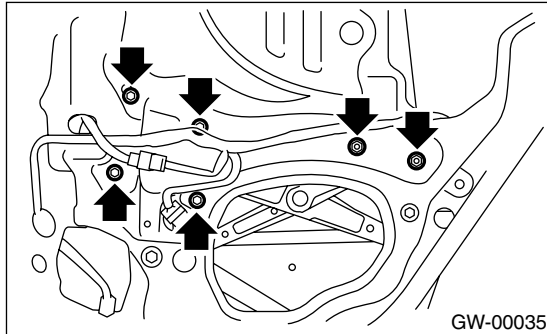

- 5) Loosen the screws to remove motor assembly.

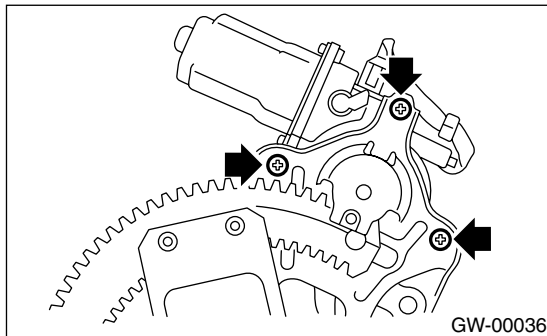

### B: INSTALLATION

- 1) Install in the reverse order of removal.
- 2) Adjust the rear door glass. <Ref. to GW-22, ADJUSTMENT, Rear Door Glass.>

#### **Tightening torque:**

**Refer to COMPONENT in General Description.** <Ref. to GW-4, REAR DOOR GLASS, COMPONENT, General Description.>

### C: INSPECTION

- 1) Make sure that the power window motor rotates properly when battery voltage is applied to the terminals of motor connector.
- 2) Change polarity of battery connections to the terminals to ensure that the motor rotates in reverse direction.

## 12. Windshield Glass

### A: REMOVAL

#### 1. USING WINDSHIELD KNIFE

- 1) Remove the cowl panel. <Ref. to EI-32, REMOVAL, Cowl Panel.>
- 2) Remove the glass molding.
- 3) Tape the body side of the circumference of windshield glass for protection.
- 4) Apply sufficient amount of soapy water to the adhesive layer.
- 5) Insert the windshield knife into the adhesive layer.
- 6) While holding the knife edge and windshield glass edge at a right angle, move the windshield knife in parallel to the windshield glass edge along face and edge of windshield glass to cut the adhesive layer.

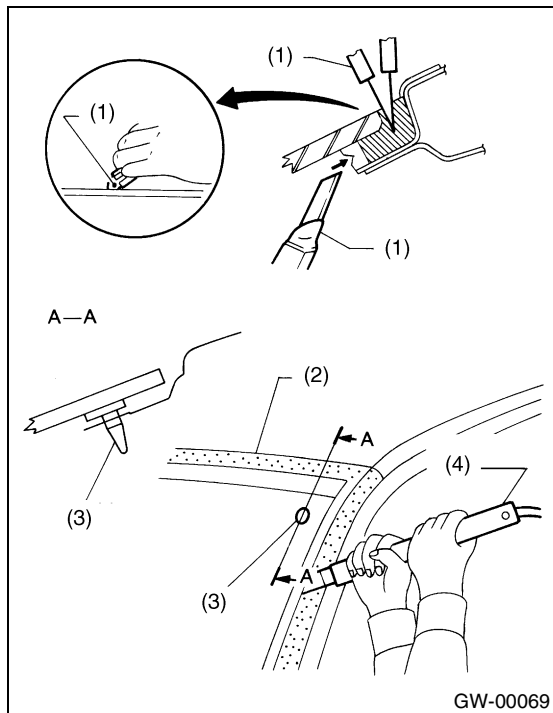

- (1) Putty knife
- (2) Protective tape
- (3) Matching pin
- (4) Windshield glass knife

**NOTE:**

Because the matching pins are bonded to the corners of glass, use piano wire to cut the pin.

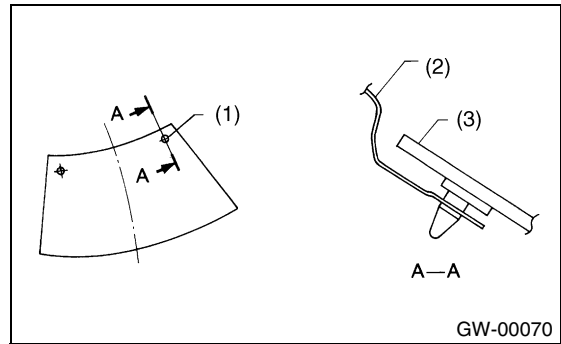

- (1) Matching pin
- (2) Body panel
- (3) Glass

#### 2. USING PIANO WIRE

- 1) Remove the cowl panel. <Ref. to EI-32, REMOVAL, Cowl Panel.>
- 2) Remove the roof molding and upper front molding.
- 3) Tape the body side of the circumference of windshield glass for protection.
- 4) Make a hole in the adhesive layer using a drill or knife.
- 5) Pass the piano wire through the hole, and attach securely both the wire ends to pieces of wood.

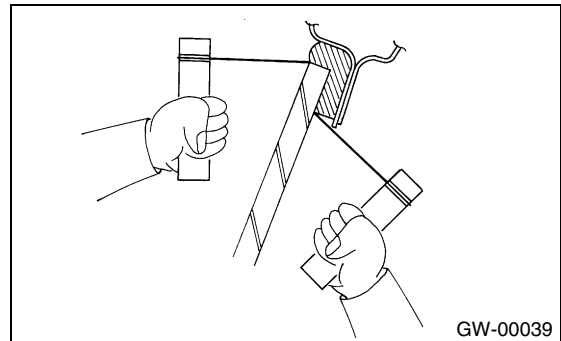

- 6) Pull the wire ends alternately to cut off the adhesive layer.



## B: INSTALLATION

- 1) Clean the external circumference of windshield glass with alcohol or white gasoline.
- 2) Remove the adhesive layer on the body using cutter knife to obtain smooth face 2 mm (0.08 in) thick.

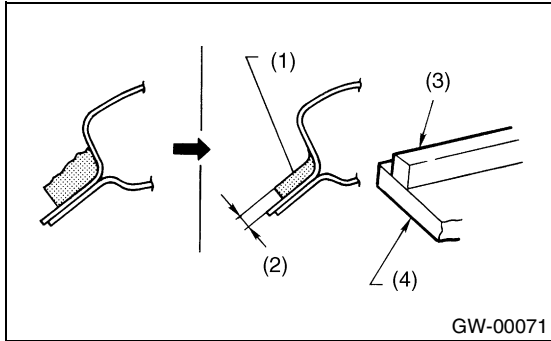

- (1) Adhesive
- (2) 2 mm (0.08 in)
- (3) Dam rubber
- (4) Glass

- 3) Clean the body with alcohol or white gasoline to remove thoroughly chips, dusts, and dirt from body face.
- 4) Apply the dam rubber to back of glass.

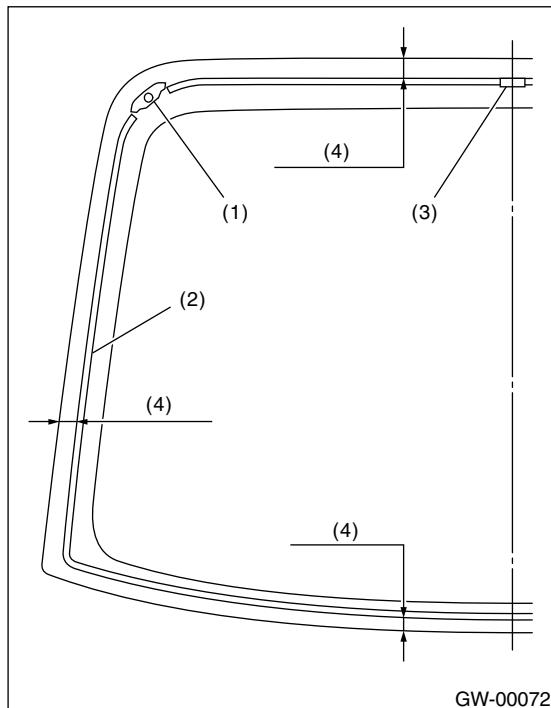

- (1) Matching pin
- (2) Dam rubber
- (3) Fastener
- (4) 13 mm (0.512 in)

- 5) Remove the backing of double-faced adhesive tape (C) and then align the molding mark (B) to notch (A). Attach the molding around the edge of glass, and then press it evenly to fit.

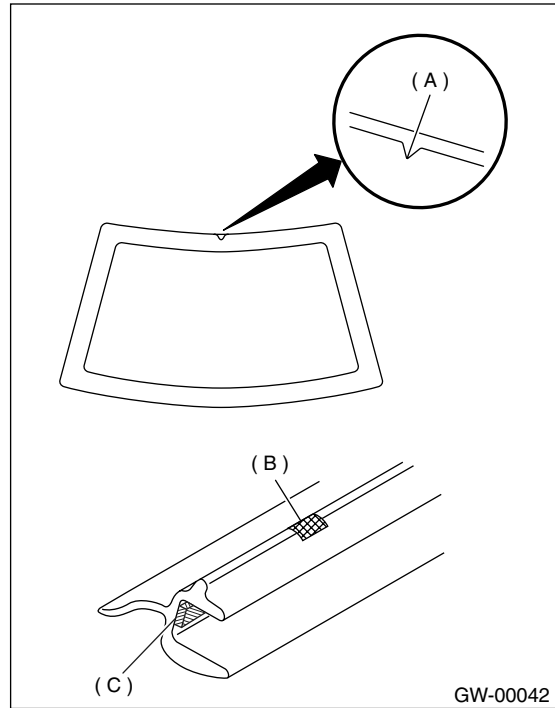

- 6) Apply primer to the adhesive layer of glass using sponge.
- 7) Apply primer to the adhesive layer of body. Primer once attached to the painted surface of the body and internal trim is hard to wipe off. Mask the circumference of such areas. Let the primer dry for about ten minutes before installing the glass.

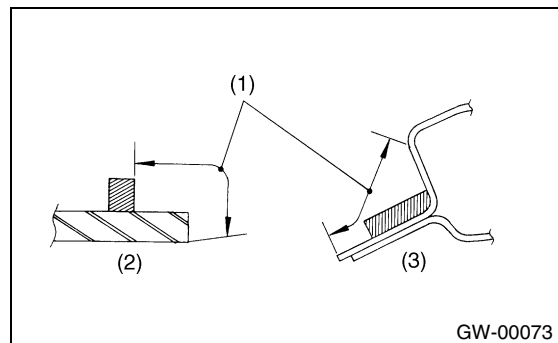

- (1) Application of primer
- (2) Glass side
- (3) Body side

# WINDSHIELD GLASS

## GLASS/WINDOWS/MIRRORS

8) Cut off the cartridge nozzle tip and set it in sealant gun as shown.

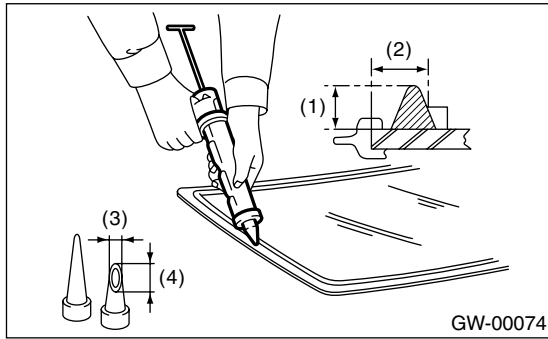

- (1) 10 — 13 mm (0.39 — 0.51 in)
- (2) 13 mm (0.51 in)
- (3) 10 mm (0.39 in)
- (4) 15 mm (0.59 in)

9) Apply adhesive to the glass end surface as shown.

10) Fit the matching pins using suction rubber cup to install the windshield glass.

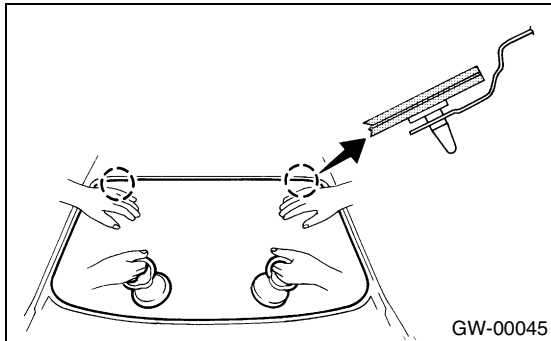

- 11) Lightly press the windshield glass for tight fit.
- 12) After completion of all work, allow the vehicle to stand for about 24 hours.

### NOTE:

For minimum drying time and time the vehicle must be left standing before driving after bonding, follow instructions or instruction manual from the adhesive manufacturer.

13) After curing of adhesive, pour water on external surface of vehicle to check that there are no water leaks.

### NOTE:

When a vehicle is returned to the user, tell him or her that the vehicle should not be subjected to heavy impact for at least three days.

14) Install the cowl panel. <Ref. to EI-32, INSTALLATION, Cowl Panel.>

## 13.Inner Rearview Mirror

### A: REMOVAL

#### NOTE:

The spring cannot be reused. Prepare a new spring before removal.

1) Turn the mirror base 90 degrees clockwise or counterclockwise to remove it.

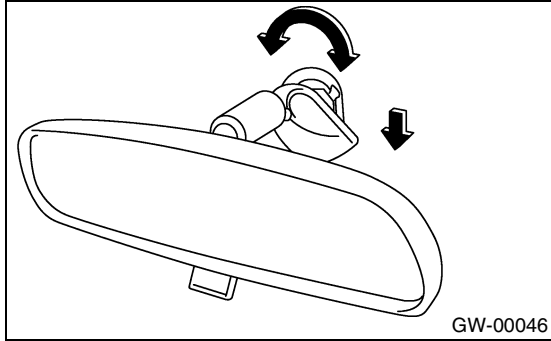

2) Remove the spring from mirror base.

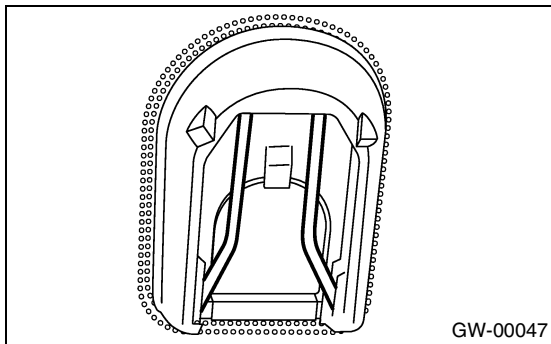

#### CAUTION:

Be careful not to damage the mirror surface.

### B: INSTALLATION

Install in the reverse order of removal.

### C: INSPECTION

Do not let the mirror be damaged.

Do not let the spring deteriorate.

# REAR GATE GLASS

GLASS/WINDOWS/MIRRORS

## 14. Rear Gate Glass

### A: REMOVAL

- 1) Remove the rear gate garnish. <Ref. to WW-17, REMOVAL, Rear Gate Garnish.>
- 2) Remove the electrical connector from rear defogger terminal.
- 3) Remove the glass in same procedure as for windshield glass. <Ref. to GW-24, REMOVAL, Windshield Glass.>

#### NOTE:

A matching pin is cemented to corners of the glass on the compartment side. Use a piano wire when cutting each pin.

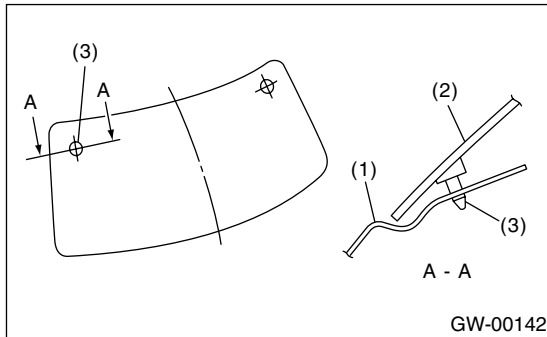

- (1) Body panel
- (2) Glass
- (3) Matching pin

### B: INSTALLATION

- 1) Install a new rubber strip (A) by aligning it with the end of the rear gate glass (B).

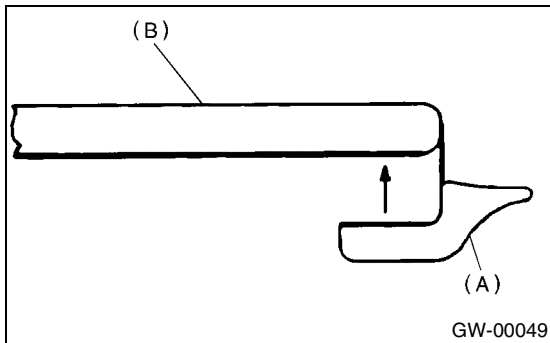

- 2) Install the glass in same procedure as for windshield glass. <Ref. to GW-20, INSPECTION, Front Regulator and Motor Assembly.>

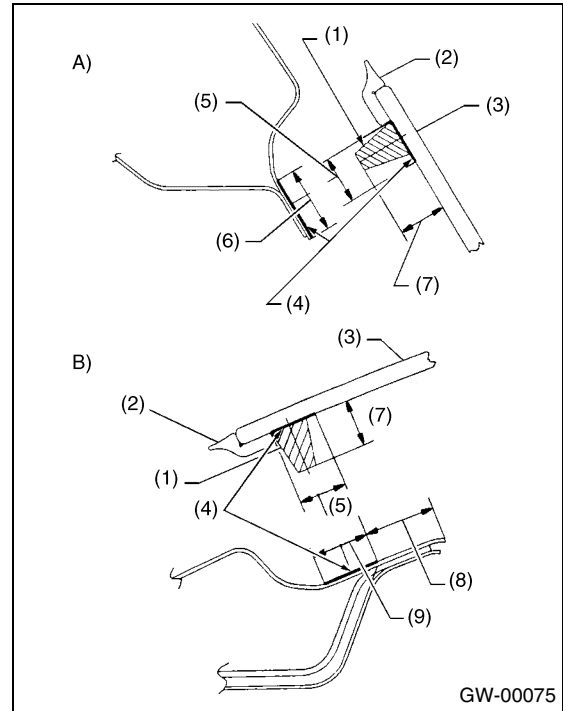

- A) Upper side
- B) Left and right side
- (1) Adhesive
- (2) Strip rubber
- (3) Glass
- (4) Primer
- (5) 12 mm (0.47 in)
- (6) 14 mm (0.55 in)
- (7) 10 — 13 mm (0.39 — 0.51 in)
- (8) 15 mm (0.31 in)
- (9) 12 mm (0.47 in)

- 3) About one hour after installation, conduct a leak test.
- 4) After completion of all work, allow the vehicle to stand for about 24 hours.

#### NOTE:

- For minimum drying time and time the vehicle must be left standing before driving after bonding, follow instructions or instruction manual from the adhesive manufacturer.
- When a vehicle is returned to the user, tell him or her that the vehicle should not be subjected to heavy impact for at least three days.
- 5) Connect the rear defogger terminals.
- 6) Install the rear gate garnish. <Ref. to WW-17, INSTALLATION, Rear Gate Garnish.>

## 15.Rear Window Defogger System

### A: SCHEMATIC

#### 1. REAR WINDOW DEFOGGER

<Ref. to WI-208, SCHEMATIC, Rear Window Defogger System.>

### B: INSPECTION

Symptom	Repair order
Rear window defogger does not operate.	(1) Fuse (M/B No. 1) (F/B No. 17) (2) Rear defogger relay (3) Rear defogger timer (4) Defogger switch (5) Rear defogger condenser (6) Defogger wire (7) Wire harness

# REAR WINDOW DEFOGGER

GLASS/WINDOWS/MIRRORS

## 16.Rear Window Defogger

### A: INSPECTION

- 1) Turn the ignition switch to ON.
- 2) Turn the defogger switch to ON.
- 3) Wrap the tips of tester pins with aluminum foil to avoid damage to heat wire.

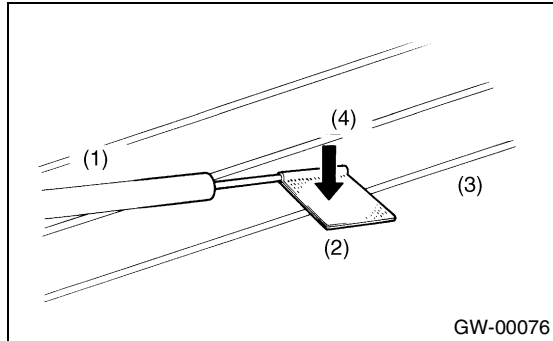

- (1) Tester probe
- (2) Tin foil
- (3) Heat wire
- (4) PRESS

- 4) Measure the voltage at wire center with DC voltmeter.

### Standard voltage:

**Approx. 6 V**

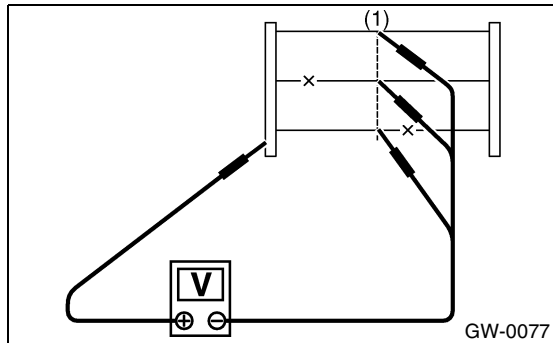

- (1) Center

Voltage	Criteria
Approx. 6 V	OK
Approx. 12 V or 0 V	Broken

### NOTE:

- If the measured value is 12 volts, heat wire is open between wire center and positive (+) end.
- If zero volt, heat wire is open between wire center and ground.

- 5) Apply positive lead of voltmeter to positive terminal of heat wire, and then move the negative lead along the wire up to negative terminal end. If voltage changes from zero to several volts during

movement of lead, heat wire is open at the voltage change point.

### B: REPAIR

- 1) Clean the broken portion with alcohol or white gasoline.
- 2) Mask both side of wire with thin film.
- 3) Apply conductive silver composition (DUPONT No. 4817) to broken portion.

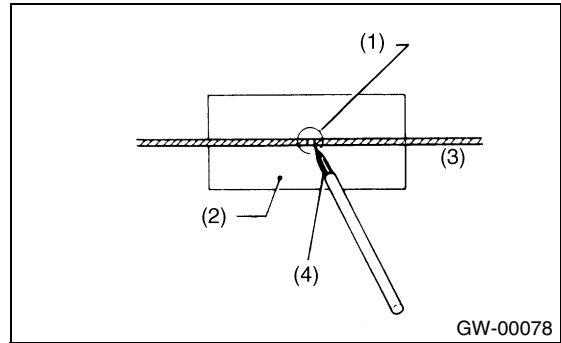

- (1) Broken portion
- (2) Masking thin film
- (3) Broken wire
- (4) Conductive silver composition

- 4) After repair, check the wire.

# 17.Rear Quarter Glass

## A: REMOVAL

Remove the glass in the same procedure as for windshield glass. <Ref. to GW-24, REMOVAL, Windshield Glass.>

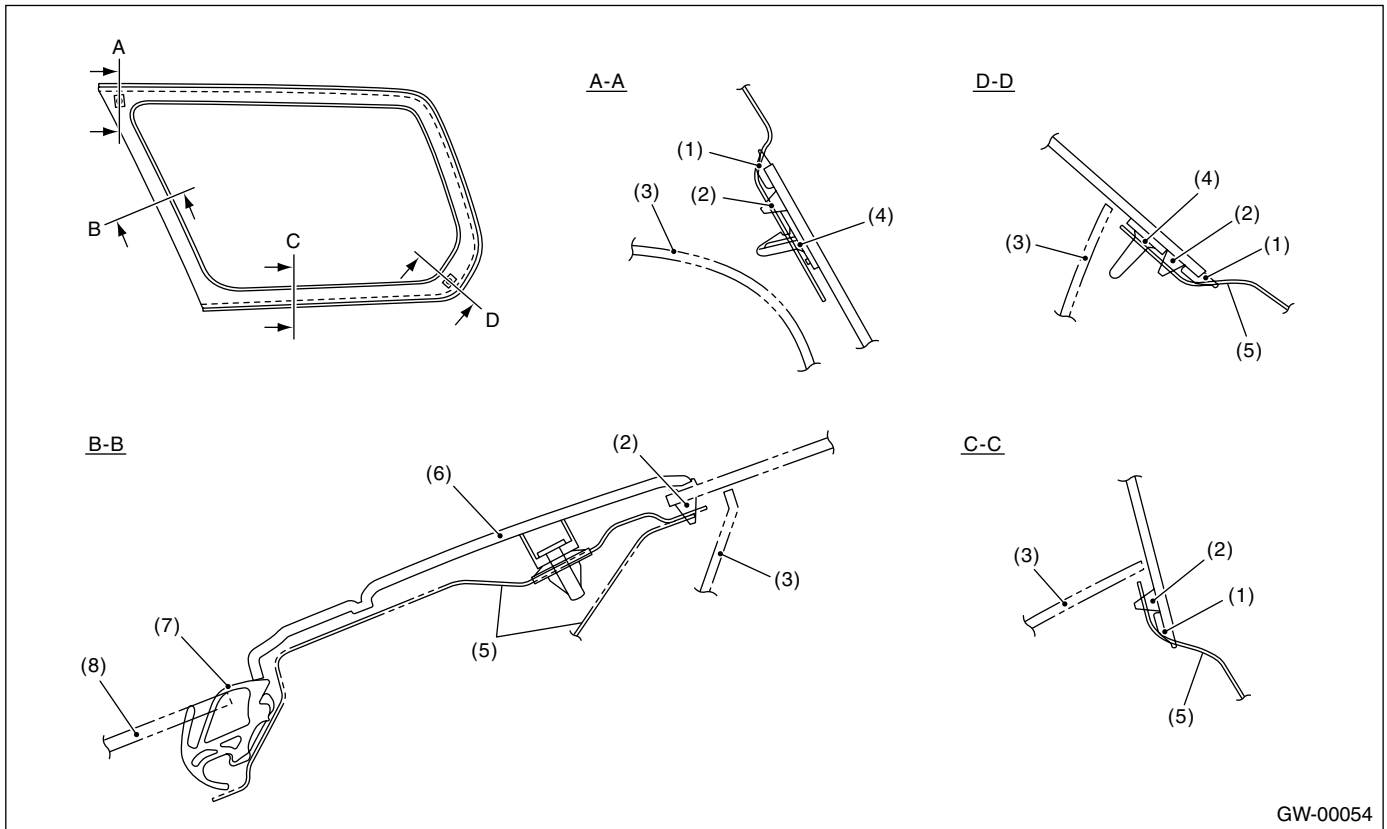

GW-00054

- |                   |                    |                     |
|-------------------|--------------------|---------------------|
| (1) Molding       | (4) Locating pin   | (7) Weatherstrip    |
| (2) Adhesive      | (5) Body           | (8) Rear door glass |
| (3) Interior trim | (6) Cover C pillar |                     |

## B: INSTALLATION

1) Cut off the nozzle tip as shown in the figure.

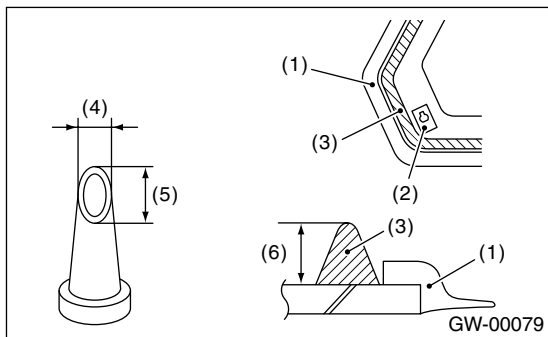

GW-00079

- |                                 |
|---------------------------------|
| (1) Molding                     |
| (2) Matching pin                |
| (3) Adhesive                    |
| (4) 10 mm (0.39 in)             |
| (5) 15 mm (0.59 in)             |
| (6) 10 — 13 mm (0.39 — 0.51 in) |

2) Install the glass in the same procedure as for windshield glass. <Ref. to GW-25, INSTALLATION, Windshield Glass.>

3) After completion of all work, allow the vehicle to stand for about 24 hours.

### NOTE:

For minimum drying time and time the vehicle must be left standing before driving after bonding, follow instructions or instruction manual from the adhesive manufacturer.

4) After curing of adhesive, pour water on external surface of vehicle to check that there are no water leaks.

### NOTE:

When a vehicle is returned to the user, tell him or her that the vehicle should not be subjected to heavy impact for at least three days.

## 18.Roof Window Glass

### **A: REMOVAL**

<Ref. to SR-5, REMOVAL, Sunroof Lid.>

### **B: INSTALLATION**

<Ref. to SR-5, INSTALLATION, Sunroof Lid.>

### **C: ADJUSTMENT**

<Ref. to SR-5, ADJUSTMENT, Sunroof Lid.>



# BODY STRUCTURE

# *BS*

---

Refer to G8071GZ SUPPLEMENT for this section.

Page

